

### ENGINE SYSTEM

- Mitsubishi® S4L2
- Diesel fueled
- EPA Tier 4
- 4 cylinder
- 1.76 L displacement
- Liquid cooled
- Power @ 1,800 rpm – HP (kW):
  - Prime: 23.5 (17.5)
  - Standby: 24.7 (18.4)

### Fuel System

- Polyethylene tank – 56.4 gal (213.5 L) usable fuel volume
- Fuel consumption – gal/hr (L/hr):
  - 100% load: 1.36 (5.15)\*
- Exterior fill port diameter: 3.5 in (88.9 mm)
- Fuel filter with replaceable element

### Cooling System

- Air filter: Dry type cartridge
- Cooling system capable of operating at 120°F (49°C) ambient

### Lubrication System

- Oil filter: Full flow, spin-on type
- 1,000-hr service interval\*\*

*\*Results based on engine manufacturer and field test data after 100-hour engine break-in period and may vary based on factors including age and maintenance of equipment, environmental conditions and fuel density. Consult the Owner's Manual for fuel and maintenance recommendations.*

*\*\*To achieve maximum service interval, replacement of oil filter after 50-hour break-in period is required. Consult Owner's Manual for required oil filter model number.*



### GENERATOR

- 60 Hz engine/generator
- Marathon Electric® brushless
- Up to 15 kW output
- 120/240 VAC, 50/25 A
- ± 6% AVR

### CONTROLS

- Engraved, aluminum punched and anodized control panel
- 4-position key activated switch (off, run, glow, start)
- Digital hour meter
- Automatic low oil/high temperature shutdown system

## FLOODLIGHTS

- Four [4] 1,100 watt metal halide
  - Lm/bare bulb: 132,000
  - Lm/fixture: 70,356
  - Total bare bulb lm: 528,000
  - Total fixture lm: 281,424
- Efficiency: 120 LPW
- Coverage: @ 0.5 ft-c: 39,241 ft<sup>2</sup> (3,646 m<sup>2</sup>)
- Oval aluminum reflector
- Tempered glass lens
- Silicone gaskets for moisture and dust protection
- Friction disc mounting for tool less positioning
- Individual floodlight On/Off switches

## ELECTRICAL SYSTEM

- 70A start trip breaker (ensures no-load condition exists at start-up)
- Floodlight circuits with sealed 15A breakers
- Ballast Indicator lights
- Convenience receptacles with individual breakers:
  - (2) 120 VAC 20 Amp GFCI duplex outlets (NEMA 5-20R type)
  - (2) 240 VAC, 30 A, twistlock outlet (NEMA L6-30R type)
  - (2) 240 VAC, 50 A, twistlock outlet (Non-NEMA 6369)
- 440CCA CCA wet cell battery

## MAST

- Horizontal mast; 30 ft. (9.14 m) maximum extension, 3-section
- Tubular steel frame – 3 in. (76.2 mm) square tube with 3/16 in. (4.78 mm) wall
- Urethane guides on all sides of mast tubes
- Industrial black powder coat finish
- Dual winch system located at ergonomic height allowing single person operation
- 359° ground-level rotation with locking system
- Coiled mast cord

## ENCLOSURE

- Steel enclosure – 14-gauge
  - UV & fade resistant, high temperature cured, white polyester powder paint
  - 68 dB(A) at 23 ft. (7 m) – prime power
- Stainless steel hinges on doors
- Multi-lingual operating/safety decals
- License plate holder with light
- Manual holder with operating manual
- Equipped with single lifting eye and fork pockets

## TRAILER

- Removable tongue – 48 in. (1219.20 mm) long
- (4) 2000 lb. (907.18 kg) adjustable leveling jacks – 4 point stance
- All jacks transport and lock in horizontal position for storage
- Side outriggers – 140 in. (3.56 m) span

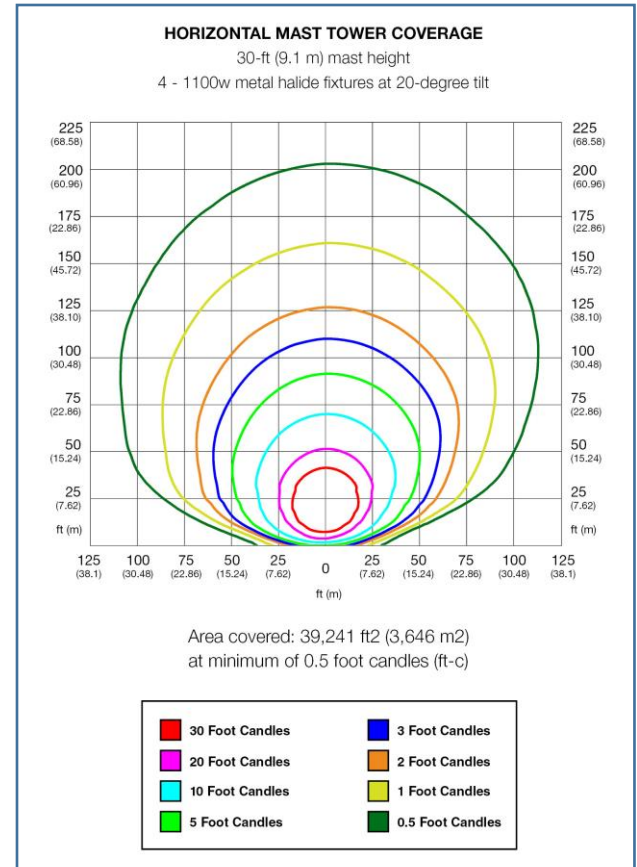

- 7800 lb. (3538 kg) safety chains with spring loaded safety hooks
- 2 in. (50.8 mm) ball hitch
- Single wall polyethylene fenders
- DOT approved tail, side, brake, and directional lights
  - Recessed rear lights
- 3000 lb. (1361 kg) leaf spring axle
- P205/75R15 – 6 ply
- 58 in. (1473 mm) axle span

## WEIGHT

- Dry weight: 2015 lbs. (914 kg)
- Operating weight: 2413 lbs. (1095 kg)

## DIMENSIONS

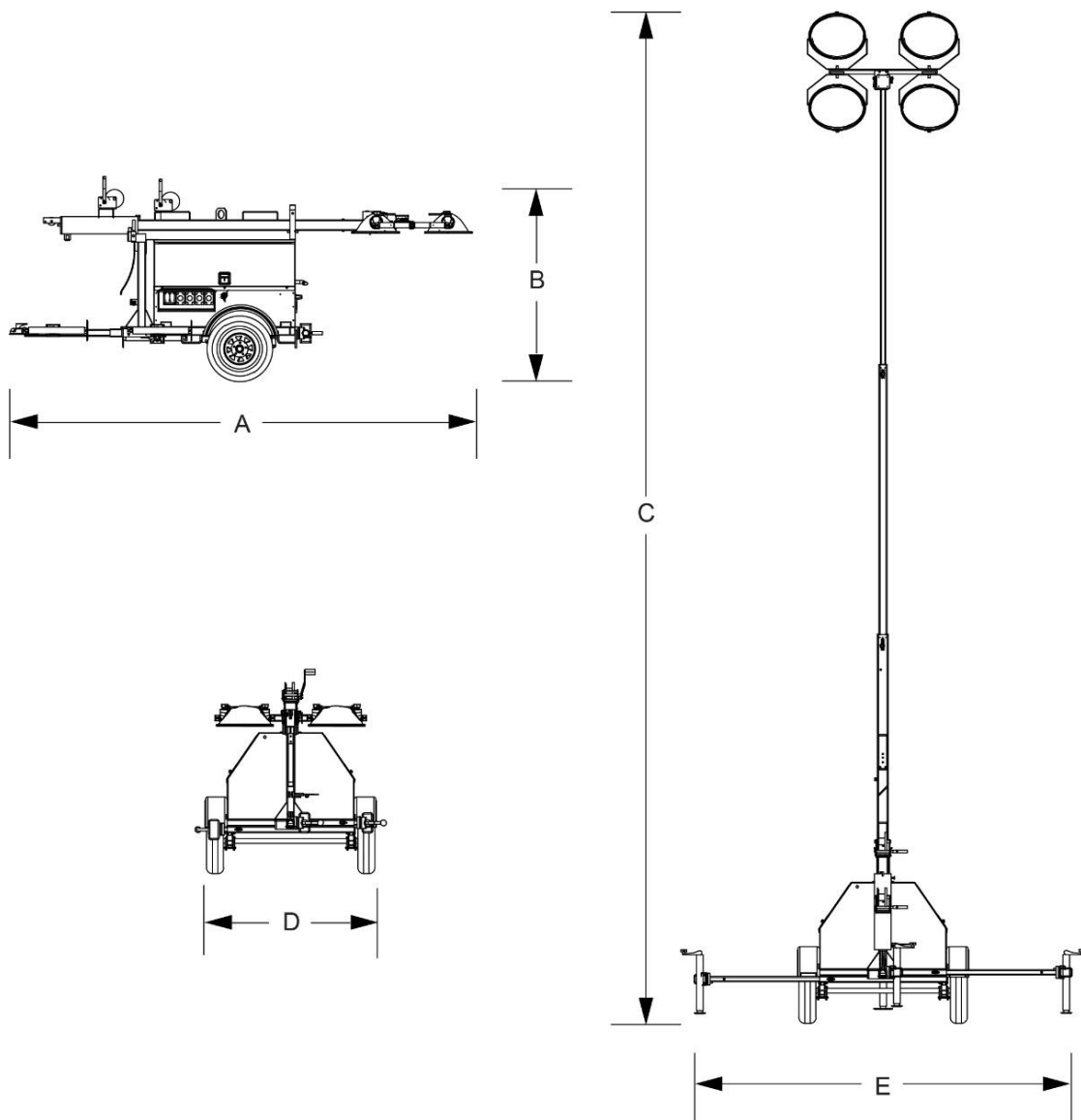

A	B	C	D	E
170 in (4.32 m)	70 in (1.78 m)	30 ft (9.14 m)	68 in (1.73 m)	140 in (3.56 m)

**OPTIONS**

- Digital Power Zone Controller
- Cold weather package options
- Canadian Package (CAN)
  - 60/40 coolant
  - Radiator hose heater
  - Heated fuel filter
  - 775CCA AGM sealed battery
  - Liquid containment
- Additional options available. Please contact a sales representative or the factory for current options.

**WARRANTY**

- 1 Year / Unlimited Hours
- 2 Years / 2000 Hours

**CERTIFICATIONS**

CSA Certified

**FOR MORE INFORMATION**

Owner's manual is available at [www.generacmobileproducts.com/resources-tools/manuals](http://www.generacmobileproducts.com/resources-tools/manuals).