

ENGINE SYSTEM

- Kubota® D1105-E3BG
- Diesel fueled
- EPA Tier 4
- 3 cylinder
- 1.12 L displacement
- Liquid cooled
- Power @ 1,800 rpm – HP (kW):
 - Prime: 13.5 (10.07)
 - Standby: 15.4 (11.48)

Fuel System

- Polyethylene tank – 56.4 gal (213.5 L) usable fuel volume
- Fuel consumption – gal/hr (L/hr):
 - 100% load: 0.814 (3.08)*
- Exterior fill port diameter: 3.5 in (88.9 mm)
- Fuel filter with replaceable element

Cooling System

- Air filter: Dry type cartridge
- Cooling system capable of operating at 120°F (49°C) ambient

Lubrication System

- Oil filter: Full flow, spin-on type
- 1,000-hr service interval*

**Results based on engine manufacturer and field test data after 100-hour engine break-in period and may vary based on factors including age and maintenance of equipment, environmental conditions and fuel density. Consult the Owner's Manual for fuel and maintenance recommendations.*

GENERATOR

- 60 Hz engine/generator
- Marathon Electric® brushless
- Up to 8kW standby output
- 120/240 VAC, 66/33 A
- ± 6% capacitor voltage regulation

CONTROLS

- Engraved, aluminum punched and anodized control panel
- 4-position key activated switch (off, run, glow, start)
- Digital hour meter
- Automatic low oil/high temperature shutdown system



FLOODLIGHTS

- Four [4] 1,100 watt metal halide
 - Lm/bare bulb: 132,000
 - Lm/fixture: 70,356
 - Total bare bulb lm: 528,000
 - Total fixture lm: 281,424
- Efficiency: 120 LPW
- Coverage: @ 0.5 ft-c: 39,241 ft² (3,646 m²)
- Oval aluminum reflector
- Tempered glass lens
- Silicone gaskets for moisture and dust protection
- Friction disc mounting for tool less positioning
- Individual floodlight On/Off switches

ELECTRICAL SYSTEM

- 40 A start trip breaker (ensures no-load condition exists at start-up)
- Floodlight circuits with sealed 15A breakers
- Ballast Indicator lights
- Convenience receptacles with individual breakers:
 - (2) 120 VAC 20 Amp GFCI duplex outlets (NEMA 5-20R type)
 - (1) 240 VAC, 30 A, twistlock outlet (NEMA L6-30R type)
- 440CCA CCA wet cell battery

MAST

- Wind Rating: 65 mph (105 kph)
- Horizontal mast; 30 ft. (9.14 m) maximum extension, 3-section
- Dual winch system located at ergonomic height allowing single person operation
- Urethane guides on all sides of mast tubes
- Industrial black powder coat finish
- 359° ground-level rotation with locking system
- Coiled mast cord

ENCLOSURE

- Steel enclosure – 14-gauge
 - UV & fade resistant, high temperature cured, white polyester powder paint
 - 68 dB(A) at 23 ft. (7 m) – prime power
- Stainless steel hinges on doors
- Multi-lingual operating/safety decals
- License plate holder with light
- Manual holder with operating manual
- Equipped with single lifting eye and fork pockets

TRAILER

- Removable tongue – 48 in. (1219.20 mm) long
- (4) 2000 lb. (907.18 kg) adjustable leveling jacks – 4 point stance
- All jacks transport and lock in horizontal position for storage
- Side outriggers – 140 in. (3.56 m) span
- 7800 lb. (3538 kg) safety chains with spring loaded safety hooks
- 2 in. (50.8 mm) ball hitch

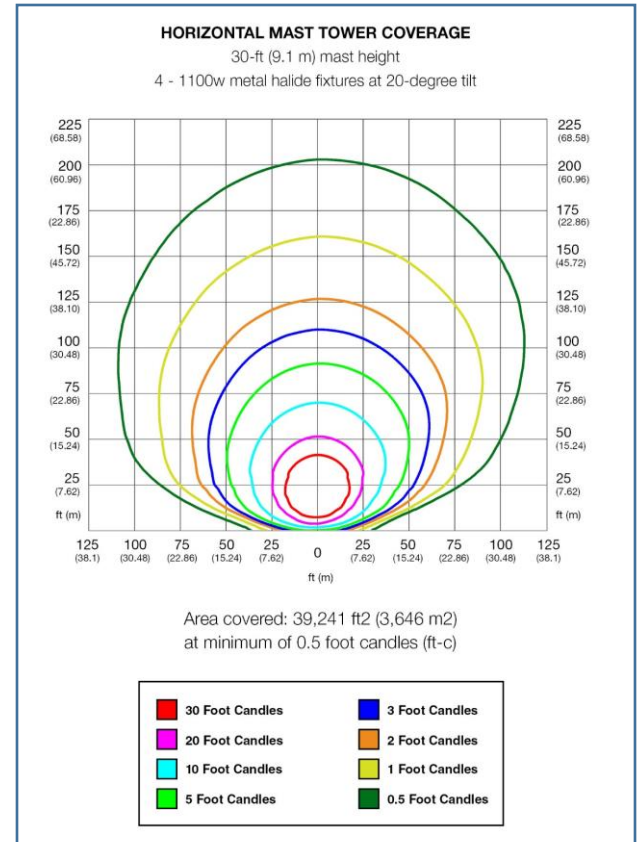

- Single wall polyethylene fenders
- DOT approved tail, side, brake, and directional lights
 - Recessed rear lights
- 2200 lb. (998 kg) leaf spring axle
- ST175/80D13 – 6 ply
- 56 in. (1422.4 mm) axle span

WEIGHT

- Dry weight: 1712 lbs. (777 kg)
- Operating weight: 1925 lbs. (874 kg)

DIMENSIONS

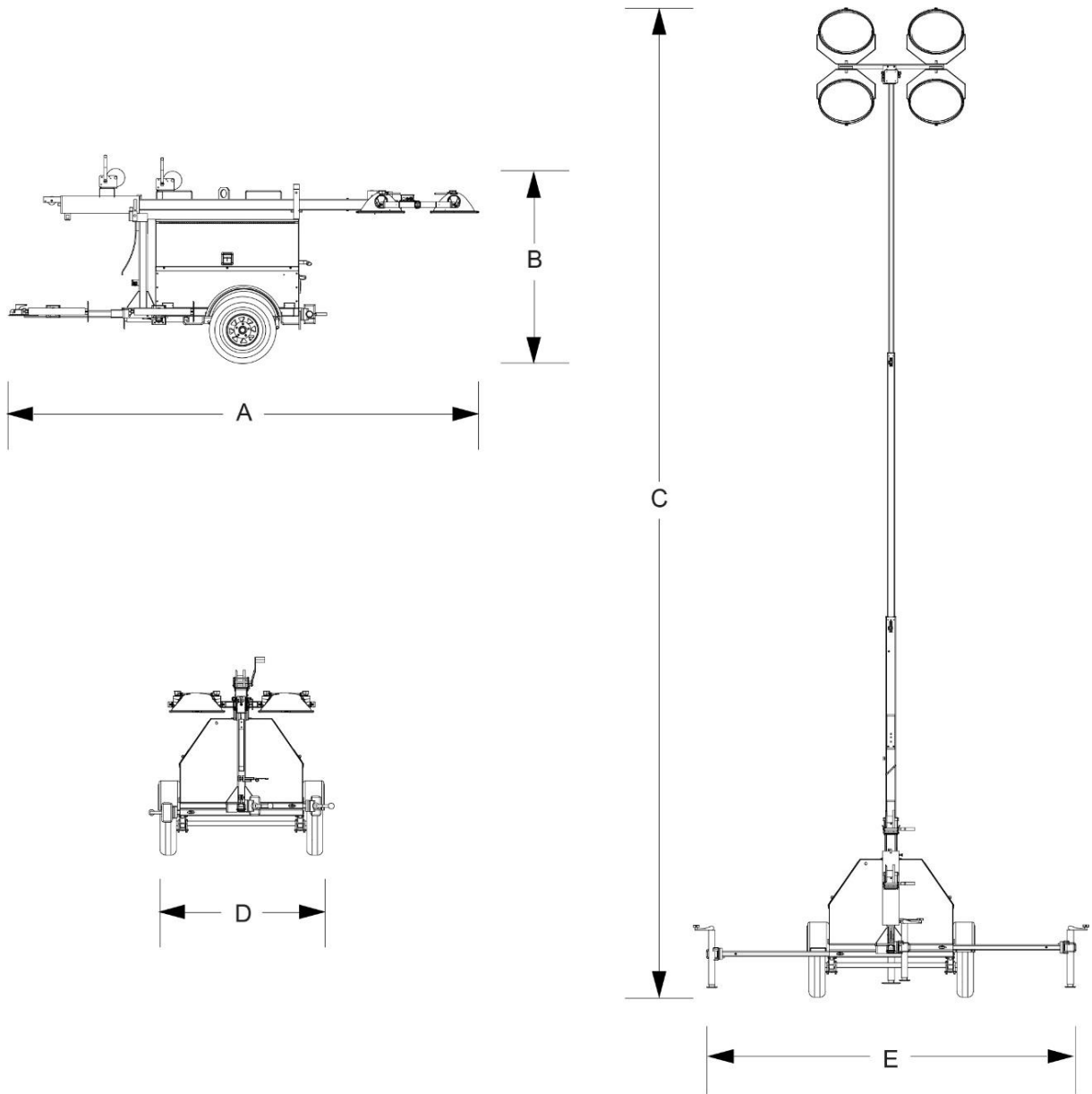

A	B	C	D	E
170 in (4.32 m)	70 in (1.78 m)	30 ft (9.14 m)	68 in (1.73 m)	140 in (3.56 m)

OPTIONS

- Digital Power Zone Controller
- Cold weather package options
- Canadian Package (CAN)
 - 60/40 coolant
 - Radiator hose heater
 - Heated fuel filter
 - 775CCA AGM sealed battery
 - Liquid containment
- Additional options available. Please contact a sales representative or the factory for current options.

WARRANTY

- 1 Year / Unlimited Hours
- 2 Years / 2000 Hours

CERTIFICATIONS

CSA Certified

FOR MORE INFORMATION

Owner's manual is available at www.generacmobileproducts.com/resources-tools/manuals.