

### ENGINE SYSTEM

- Mitsubishi® L3E-W461ML
- Diesel fueled
- EPA Tier 4
- 3 cylinder
- .95 L displacement
- Liquid cooled
- Power @ 1,800 rpm – HP (kW):
  - Prime: 10.5 (7.8)
  - Standby: 12.2 (9.1)

### Fuel System

- Polyethylene tank – 30 gal (113.6 L) usable fuel volume
- Fuel consumption – gal/hr (L/hr):
  - 100% load: 0.59 (2.23)\*
- Exterior fill port diameter: 3.5 in (88.9 mm)

### Cooling System

- Air filter: Dry type cartridge

### Lubrication System

- Oil filter: Full flow, spin-on type
- 1,000-hr service interval\*\*

*\*Results based on engine manufacturer and field test data after 100-hour engine break-in period with 30 useable gallons in fuel tank. Actual results may vary based on factors including age and maintenance of equipment, environmental conditions and fuel density. Consult the Owner's Manual for fuel and maintenance recommendations.*

*\*\*To achieve maximum service interval, replacement of oil filter after 50-hour break-in period is required. Consult Owner's Manual for required oil filter model number.*

### GENERATOR

- 60 Hz engine/generator
- Marathon Electric® brushless
- Up to 6 kW output
- 120/240 VAC, 50/25 A
- ± 6% capacitor voltage regulation

### CONTROLS

- Engraved, aluminum punched and anodized control panel
- 4-position key activated switch (off, run, glow, start)
- Digital hour meter
- Automatic low oil/high temperature shutdown system



## FLOODLIGHTS

- Four [4] 1,100 W metal halide
  - Lm/bare bulb: 132,000
  - Lm/fixture: 70,356
  - Total bare bulb lm: 528,000
  - Total fixture lm: 281,424
- Efficiency: 120 LPW
- Coverage: @ 0.5 ft-c: 31,902 ft<sup>2</sup> (2,964 m<sup>2</sup>)
- Oval aluminum reflector
- Tempered glass lens
- Silicone gaskets for moisture and dust protection
- Friction disc mounting for tool less positioning
- Individual floodlight On/Off switches

## ELECTRICAL SYSTEM

- 30 A start trip breaker (ensures no-load condition exists at start-up)
- Floodlight circuits with sealed 15 A breakers
- Ballast Indicator lights
- Convenience receptacles with individual breakers:
  - Two 120 VAC 20 Amp GFCI duplex outlets (NEMA 5-20R type)
  - One 240 VAC, 30 A, twistlock outlet (NEMA L6-30R type)
- 440CCA CCA wet cell battery

## MAST

- Vertical operation and storage
- Maximum height: 25 ft (7.62 m)
- Five sections, tubular steel
- Distinctive angle fixture design for consistent light distribution
- Electric winch standard
- 950 lb. (430.91 kg) automatic self-breaking electric winch – easily raises mast vertically
- 359° ground-level rotation with locking system
- Coiled mast cord

## ENCLOSURE

- Steel enclosure – 14-gauge
  - UV & fade resistant, high temperature cured, white polyester powder paint
  - 68 dB(A) at 23 ft. (7 m) – prime power
- Stainless steel hinges on doors
- Multi-lingual operating/safety decals
- License plate holder with light
- Manual holder with operating manual
- Equipped with single lifting eye and fork pockets

## TRAILER

- Front step platform for easy adjustment of light fixtures
- Removable tongue – 48 in. (1219.20 mm) long
- Tubular steel frame – 3/16 in. (4.78 mm) wall
- (4) 2000 lb. (907.18 kg) adjustable leveling jacks – 4 point stance
- All jacks transport and lock in horizontal position for storage

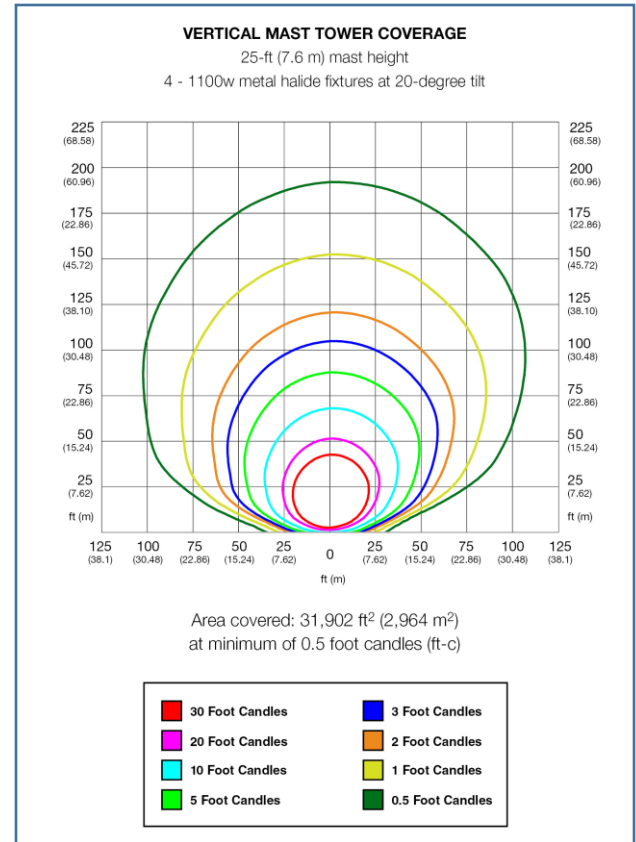

- Side outriggers – 96.25 in. (2.45 m) span
- 7800 lb. (3538 kg) safety chains with spring loaded safety hooks
- 2 in. (50.8 mm) ball hitch
- Single wall polyethylene fenders
- DOT approved tail, side, brake, and directional lights
  - Recessed rear lights
- 2200 lb. (997.90 kg) leaf spring axle
- ST175/80D13 – 6 ply
- 40.75 in. (1035.05 mm) axle span

## OPTIONS

- Digital Power Zone Controller
- Cold weather package options
- Additional options available. Please contact a sales representative or the factory for current options.

## DIMENSIONS

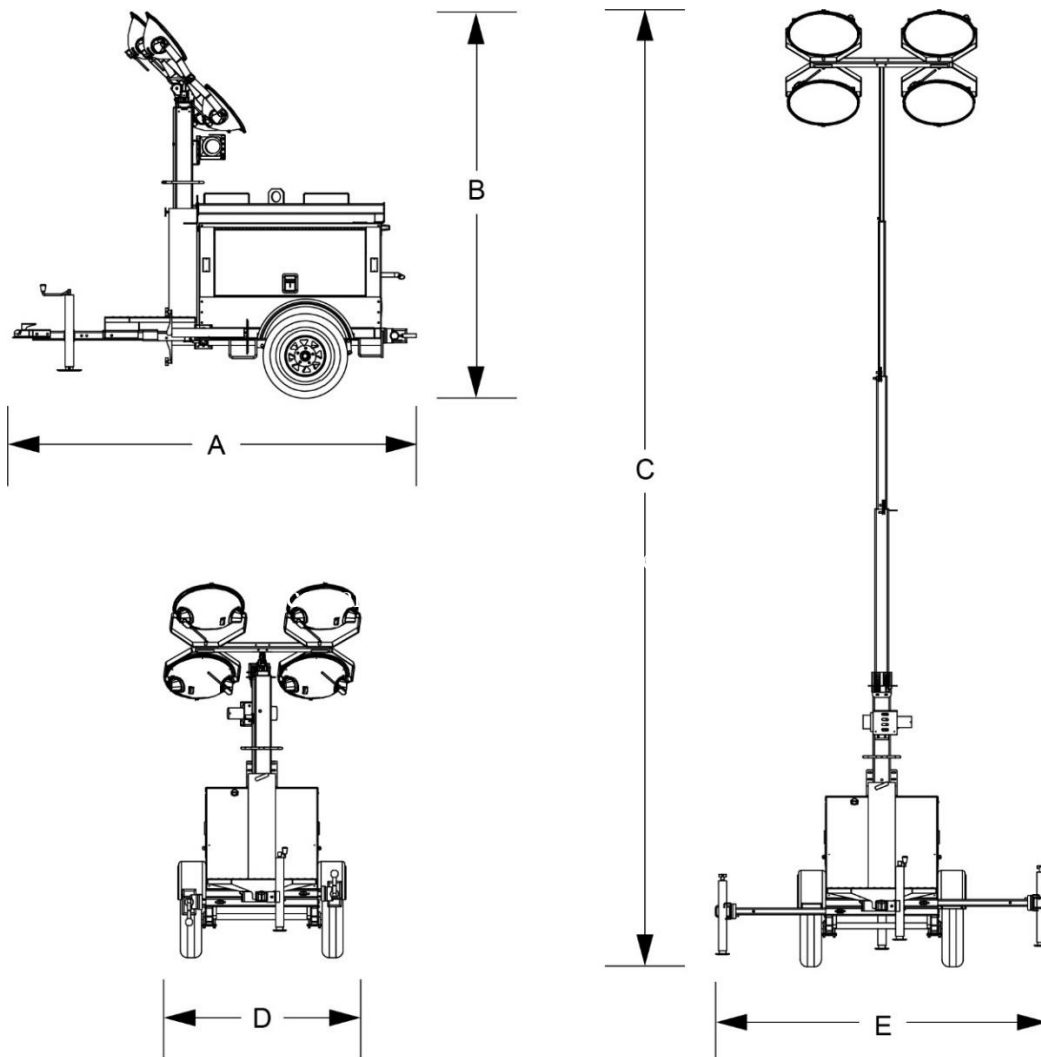

A	B	C	D	E
117 in (3 m)	111 in (2.8 m)	25 ft (7.6 m)	58 in (1.5 m)	98 in (2.5 m)

**WEIGHT**

- Dry weight: 1694 lbs. (768 kg)
- Operating weight: 1910 lbs. (866 kg)

**WARRANTY**

- 1 Year / Unlimited Hours
- 2 Years / 2000 Hours

**CERTIFICATIONS**

CSA Certified

**FOR MORE INFORMATION**

Owner's manual is available at [www.generacmobileproducts.com/resources-tools/manuals](http://www.generacmobileproducts.com/resources-tools/manuals).