

MDG75DF4 | 4.5 L | 75 kVA

MOBILE DIESEL GENERATOR SET

EPA Emissions Certification: Final Tier 4



Standby Power Rating

68 kW, 85 kVA, 60 Hz

Prime Power Rating

60 kW, 75 kVA, 60 Hz



Image used for illustration purposes only

Codes and Standards

Generac Mobile products are designed to the following standards:



CSA



NATM



TIER 4 FINAL EMISSIONS



ISO 8528-5

Power When and Where You Need It

Generac Mobile diesel generators are designed and engineered to power a variety of projects, in the most extreme environments. Gensets are configured to meet customer needs, including choice of containment, cold weather packages, trailer options, and more.

Generac Mobile diesel generators are manufactured to deliver reliable power, when and where you need it.

STANDARD FEATURES

ENGINE SYSTEM

- John Deere® 4045HFG04_B
- 4 cylinder
- Turbocharged
- 275 in³ (4.5 L) displacement
- EPA Final Tier 4
- Power @ 1,800 rpm – hp (kW):
 - Prime: 97 (73)
 - Standby: 107 (80)

FUEL SYSTEM

- Fuel tank capacity – gal (L):
 - Total: 165 (625)
 - Usable: 150 (568)
- Maximum run time @ 100% load: 24 hr
- Fuel consumption @ prime – gal/hr (L/hr):
 - 25% load: 1.69 (6.37)
 - 50% load: 2.62 (10.22)
 - 75% load: 3.74 (14.18)
 - 100% load: 4.85 (18.39)
- 110% fluid containment

COOLING SYSTEM

- Capable of operating at 107 °F (41.7 °C) ambient
- Oil filter: Spin-on cartridge
- Air filter: Disposable – paper element
- Radiator and oil drains plumbed to exterior

SYSTEM OUTPUTS

- Voltage selection switch: 3-position, lockable
- Electrical power output – kW (kVA):
 - 1-phase standby: 60 (60)
 - 1-phase prime: 55 (55)
 - 3-phase standby: 68 (85)
 - 3-phase prime: 60 (75)

GENERATOR

- 60 Hz engine/generator
- Marathon Electric® 361CSL1602
 - Brushless
 - 4-pole
 - Class H insulation
- Voltage regulation ±1.0% with PM600 voltage regulator

ENCLOSURE

- Aluminum, sound attenuated enclosure
 - UV and fade resistant, high temperature cured, white polyester powder paint
 - Insulated and baffled
 - 74 dB(A) @ 23 ft (7 m) @ prime power
- Fully lockable – includes doors, fuel fill, and DEF fill
- Exterior emergency stop switch
- Central lifting point

- Multi-lingual operating and safety decals
- Document holder with owner’s manual – includes AC and DC wiring diagrams

TRAILER

- DOT approved tail, side, brake, and directional lights; recessed rear lights
- Surge brakes
- Transportation tie downs
- Safety chains with spring loaded safety hooks
- 3 in (7.62 cm) ring hitch
- Single axle – 6,000 lb (2,722 kg)

WARRANTY

- 2 year limited or 2,000 hours
 - Unlimited hours covered in first year

CERTIFICATIONS

- CSA certified

SYSTEM CONTROLS

Power Zone® Controller And Display

- Backlit, 800×480 pixel resolution color display
- -40—185 °F (-40—85 °C) operating temperature range
- Automatic coarse voltage adjustment
- Integrated fine voltage adjustment
- PLC functionality

Push Buttons For Easy Operation

- Manual or Auto start
- Engine start
- Engine stop/reset
- Alarm mute
- Operator screens:
 - Home
 - Engine
 - Generator
 - Voltage adjust

Scrolling Arrows for Diagnostic Information

- Engine diagnostic display
 - Oil pressure
 - Engine temperature
 - Fuel level
 - Battery
 - After-treatment inlet/outlet temperature
 - Ash/soot levels
- Generator diagnostic display
 - System kW output display
 - Line output and frequency display
- Alarms
 - Warning

- Shutdown
- Electrical Trip
- Engine
- Alarm list – warnings/shutdowns; 250 event history log – date/time stamp
 - Fuel level: warning – 15%; shutdown – 5%
 - Over speed protection: shutdown – 115%
 - Oil pressure: warning – 25 psi (172.4 kPa); shutdown – 20 psi (137.9 kPa)
 - Coolant temperature: warning – 230 °F (110 °C); shutdown – 235 °F (113 °C)
 - Battery voltage: over – 15 VDC; under – 11 VDC
 - Generator over voltage: warning – 110%; electrical trip – 125%
 - Generator under voltage: warning – 91.4%; shutdown – 70%
 - Generator over frequency: warning – 102.5%; electrical trip – 110%
 - Generator under frequency: warning – 95%; electrical trip – 90%

- Inputs/outputs
- Auto-schedule
- Status
- View controller functional parameters (configuration, firmware version, connections)

ELECTRICAL CONTROLS

- Remote start/stop contacts in receptacle box
- Lockable control box door with diagnostics window
- Lockable lug box with safety switch
 - Trips main breaker when door is opened
 - Disables voltage regulator
- Output ground connection lug inside lug box
- 300 A main breaker with shunt trip
- Convenience receptacles with individual breakers (restricted use in high wye mode)
 - Two 120 V, 20 A, GFCI, duplex outlets (NEMA 5-20R type)
 - Three 125/250 V, 50 A, 3-pole, 4-wire, twistlock outlets (Non-NEMA 6369)
- One 12 V, 720 CCA, wet cell battery

MDG75DF4 | 4.5 L | 75 kVA

MOBILE DIESEL GENERATOR SET

EPA Emissions Certification: Final Tier 4



OPTIONS*

ENGINE SYSTEM

- Two fuel filter heaters
- Oil pan heater
- Battery heater
- CCV multi-heater system
- 60/40 coolant
- Positive air shutdown

FUEL SYSTEM

- 110% fluid containment
- Leak detection
- Extended run fuel and DEF system

TRAILER

- Full size spare tire
- Tool box/storage bin
- 2-5/16 in (5.9 cm) ball hitch
- Electric brakes
- Rear stabilizer jacks
- 2 in (5.08 cm) ball hitch
- Tandem axle

CABINET

- Control panel light
- Interior lights

CONTROL SYSTEM

- 4-position phase switch
- PMG
- Paralleling
- Buck transformer
- Battery disconnect switch
- Cam locks
- 10 A battery charger

GENERATOR SYSTEM

- SuperStart



RATING DEFINITIONS

Standby: Applies to varying emergency load for the duration of a utility power outage.

Prime: Applies to supplying power to a varying load in lieu of utility for an unlimited amount of running time.

*Consult factory for availability

MDG75DF4 | 4.5 L | 75 kVA

MOBILE DIESEL GENERATOR SET

EPA Emissions Certification: Final Tier 4



APPLICATION AND ENGINEERING DATA

ENGINE SPECIFICATIONS

General

Make (Model)	John Deere (4045HFG04_B)
EPA Emissions Compliance	Final Tier 4
After Treatment System	DOC and SCR
Cylinders – Qty	4
Type	In-line
Displacement – L	4.5
Bore – in (mm)	4.2 (106)
Stroke – in (mm)	5.0 (127)
Compression Ratio	17:1
Intake Air Method	Turbo/air-to-air, after-cooled

Engine Governing

Governor	Electronic
Frequency Regulation (Steady State)	2%

Lubrication System

Oil Pump Type	Gear
Oil Filter Type	Spin-on cartridge
Crankcase Capacity – qt (L)	15.9 (15)

Cooling System

Cooling System Type	Radiator and CAC
Water Pump Type	Engine-belt driven
Fan Type	Pusher
Fan Speed – rpm	Variable Visc clutch
Fan Diameter – in (mm)	23.2 (590)
Cooling System Capacity – qt (L)	22 (20.8)

Fuel System

Fuel Type	Ultra low sulfur diesel
Fuel Specifications	EN590/ASTM D975
Fuel Filtering – μ	Primary: 10 Final: 2
Fuel Inject Pump Make	Denso HP3
Fuel Pump Type	Engine driven - belt
Injector Type	Electronic
Engine Type	Direct Injection
Fuel Supply Line Diameter – in (mm)	.313 (8.0)
Fuel Return Line Diameter – in (mm)	.313 (8.0)

Engine Electrical System

System Voltage – VDC	12
Battery Charger Alternator	STD
Battery – CCA	720
Battery – V (Qty)	12 (1)
Ground Polarity	Negative (-)

ALTERNATOR SPECIFICATIONS

Make (Model)	Marathon Electric (361CSL1602)
Poles	4
Field Type	Rotating
Insulation Class – Rotor	H
Insulation Class – Stator	H
Total Harmonic Distortion	<3.5%
Telephone Interference Factor (TIF)	<50

Standard Excitation	Brushless
Bearings	Single bearing
Coupling	Direct, flex disc
Prototype Short Circuit Test	Yes
Voltage Regulator Type	Analog
Quantity of Sensed Phases	1
Regulation Accuracy (Steady State)	$\pm 1\%$

MDG75DF4 | 4.5 L | 75 kVA

MOBILE DIESEL GENERATOR SET

EPA Emissions Certification: Final Tier 4

GENERAC®

MOBILE

OPERATING DATA

POWER RATINGS

	Standby: KW/kVA (A)	Prime: KW/kVA (A)
1-phase, 120/240 VAC @ 1.0 pf	60/60 (250)	55/55 (229)
3-phase, 120/208 VAC @ 0.8 pf	68/85 (236)	60/75 (208)
3-phase, 120/240 VAC @ 0.8 pf*	68/85 (204)	60/75 (180)
3-phase, 277/480 VAC @ 0.8 pf	68/85 (102)	60/75 (90)

*Power ratings achieved through use of optional 4-position phase switch.

STARTING CAPABILITIES (sKVA)

sKVA vs. Voltage Dip

150 kVa
25%

FUEL AND DEF CONSUMPTION RATES

Load	Fuel Consumption Rate: gal/hr (L/hr) DEF: gal/hr (L/hr)			
	@ Standby	@ Prime	@ Standby	@ Prime
25%	1.74 (6.61)	1.69 (6.37)	TBD	TBD
50%	2.85 (10.82)	2.62 (10.22)	TBD	TBD
75%	4.06 (15.38)	3.74 (14.18)	TBD	TBD
100%	5.33 (20.19)	4.85 (18.39)	TBD	0.22 (0.98)

Deration – Operational characteristics consider maximum ambient conditions. Derate factors may apply under atypical site conditions.

Please consult a Generac Mobile Products Authorized Service Dealer for additional details. All performance ratings in accordance with ISO3046, BS5514, ISO8528, ISO8665, ISO3046, SAE J1228, SAE J1995, and DIN6271 standards.

MDG75DF4 | 4.5 L | 75 kVA

MOBILE DIESEL GENERATOR SET

EPA Emissions Certification: Final Tier 4



DIMENSIONS AND WEIGHTS*

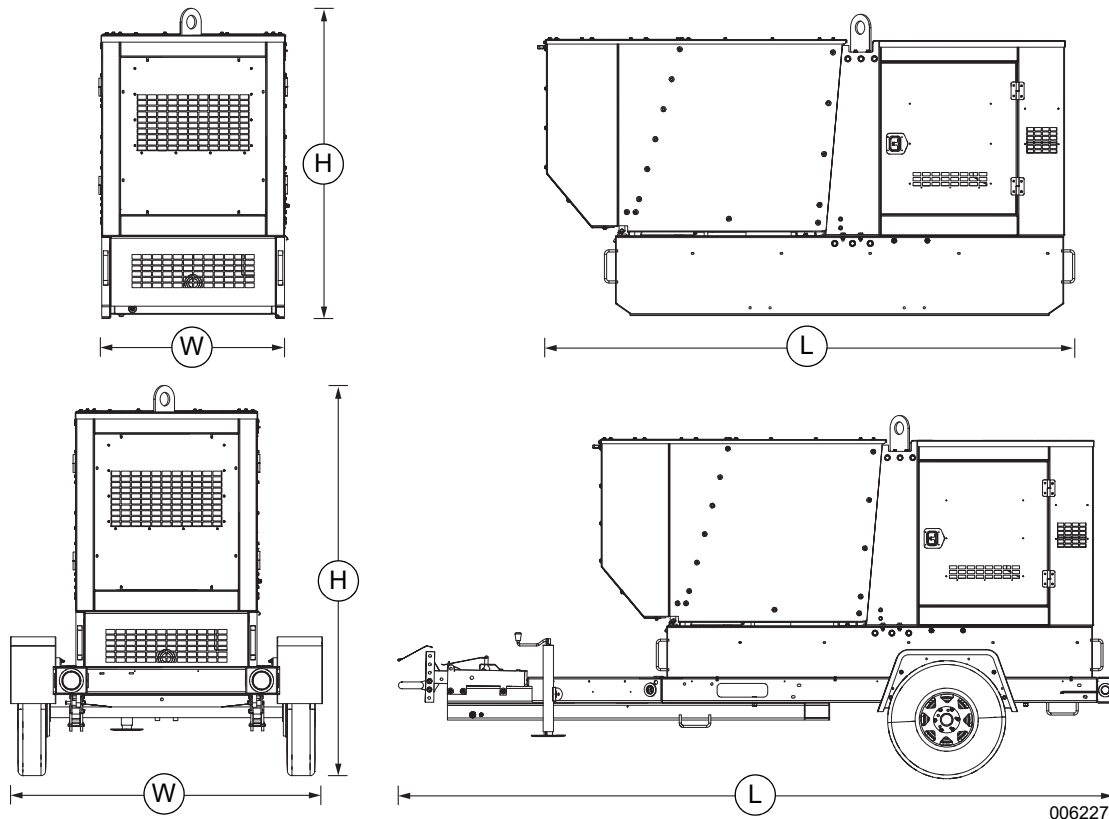

	Run Time: hr	Usable Fuel Capacity: gal (L)	Dimensions – L×W×H: in (m)	Weight: lb (kg)
Skid	26	146 (551.8)	119×40×62 (3.02×1.02×1.57)	Dry: 3,830 (1,740) Operating: 4,790 (2,170)
Trailer	26	146 (551.8)	170×69×80 (4.31×1.75×2.03)	Dry: 4,530 (2055) Operating: 5,490 (2,490)

* All measurements are approximate and for estimation purposes only.

YOUR FACTORY RECOGNIZED GENERAC MOBILE PRODUCTS DEALER

Specification characteristics may change without notice. Dimensions and weights are for preliminary purposes only. Please consult a Generac Mobile Products Authorized Service Dealer for detailed installation drawings.